

LOADMAX

Performance.
Strength.
Value.



WL200E
Spec Sheet
WHEEL LOADER

WL200E WHEEL LOADER

WL200E Features

- ROPS/FOPS Pillarless Cabin
- Fast Cycle Times
- Articulated frame
- Suspension Seat with Armrest
- Heavy Duty Hydraulic Rams
- 50 point Pre-delivery Inspection
- 2 year / 2000 hour Limited Warranty

Optional Attachments

- Air-conditioning
- Joystick Controller
- Hydraulic Quick Hitch/Aux. Hydraulics
- Pallet Forks/4in1 Bucket/GP Bucket
- Larger Tyres / Turf Tyres / Solid Tyres
- Weighing System
- Auto-Greasing System

Dimensions

A Length (Bucket on ground)	5800mm
B Width outside tyres	2200mm
C Height	2850mm
D Bucket Width	2200mm
E Max. Dump Height (-45° angle)	3400mm
F Wheel Centres	1600mm
G Max. Hinge Pin Height	4250mm
H Wheelbase	2580mm
I Length, no bucket	4900mm
J Front wheel to bucket edge	950mm

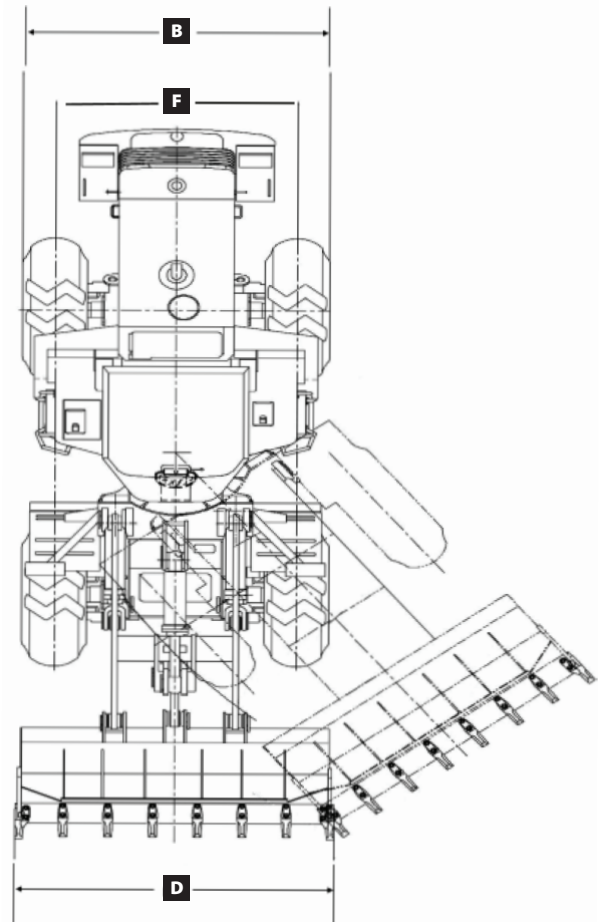
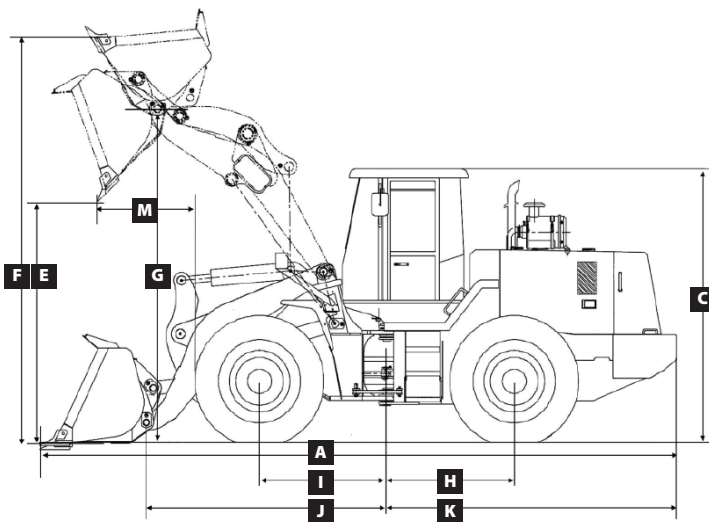

Specifications

Operating Weight	6300kg
Rated Load	2000kg
Static Tipping Load (full turn)	4000kg
Bucket Standard	1.1m ³

Max. Traction Force	3750kgf
Max Breakout force	5950kgf
Min Turning Radius Rear Wheel	4253mm
Min Turning Radius Bucket	4760mm

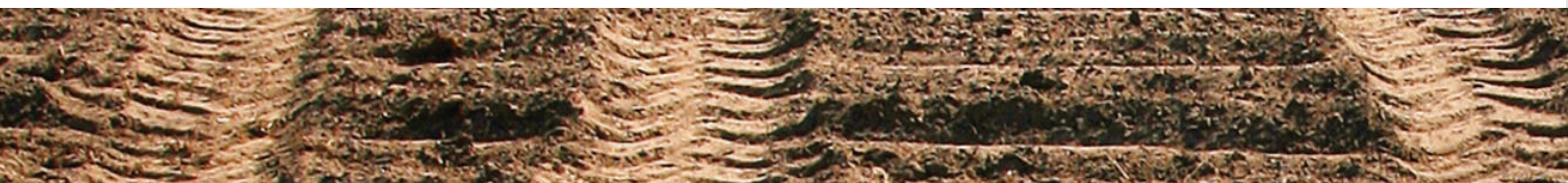

WL200E WHEEL LOADER

Transmission

Torque Converter	Type	Single phase, hydraulic convertor				
	Torque ratio	2.159				
Travel Speed	Speeds	1	2	3	4	
	Forward (km/h)	0-10	26	N/A	N/A	
	Reverse (km/h)	0-10	26	N/A	N/A	
Transmission	Type	Fixed Power Shift				
	Shift	Forward 2 / Reverse 2				
	Transmission Ratio	Forward 1				2.45
		Forward 2				0.87
		Forward 3				N/A
		Forward 4				N/A
		Reverse 1				2.50
		Reverse 2				0.89
	Transmission Pump	Gear driven hydraulic pump				
Working Pressure	2030 Psi					
Main Drive	Type	Single stage, spur gear				
	Gear Ratio	6:17				
Final Drive	Type	Single stage, planetary shift				
	Gear Ratio	4:4				
Driving Axle & Tyres	Type	4WD				
	Mount	Oscillating rear axle, rigid front axle				
	Tyre Size	16/70-20 *Optional 16/70-24				
Brake System	Service Brake Type	Air over hydraulic disc brakes				
	Parking Brake	Hand Brake				

Steering System

Type	Full hydraulic articulated steering
Steering Pump	N/A
Steering Angle	35°
Working Pressure	2030 Psi

Bucket Options

Standard Material	1.1m ³
Optional Light Material	1.5m ³

Engine

	Standard	Optional
Make	CUMMINS	
Model	4BTA3.9-C100	
Rated Power	74kW	
Rated RPM	2200rpm	
Displacement	3.9L	
Max.Torque	450Nm	
Cylinders	4	

Hydraulics

Type	Gear driven hydraulic
Boom Cylinder Cylinder bore x piston rod diameter x stroke	90x50x740mm
Bucket Cylinder Cylinder bore x piston rod diameter x stroke	125x70x387mm
Pump	Gear driven hydraulic
Working pressure	2320 Psi
Lifting time (Max Load)	6.2s
Lowering time (Empty)	3.2s
Dumping time (Empty)	1.2s
Total Cycle Time	10.6s
Max Auxiliary Flow	126 L/min

Service Fill Capacities

Fuel	97L
Hydraulic Oil	95L
Axles	2 x 8L
Engine Oil	11L
Transmission	19L
Brake System	1.4L

*Materials and specifications are subject to change without notice.

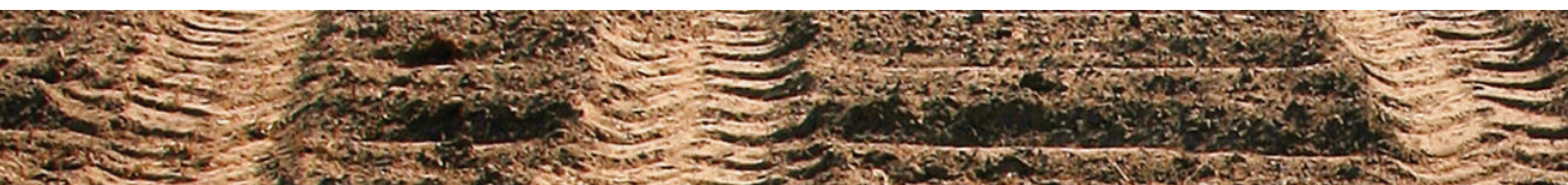

© **Endraulic** **EQUIPMENT**



0800 468 782

SERVICE AGENTS

Auckland Endraulic - Workshop | Tel 0800 468 782

Waikato Pro Mechanical | Tel 07 957 2695

Gisborne Gisborne Hydraulics Ltd | Tel 06 868 6226

Rotorua Top Gear Rotorua Ltd | Tel 0274 707 014

Taupo Taupo Parts & Services | Tel 07 378 2673

Taranaki Muggeridge Diesel Services | Tel 0274 334 747

Wanganui CRV Equipment | Tel 06 348 7860

Palmerston North Central Forklifts | Tel 06 323 1908

Horowhenua McLachlans Services | Tel 027 675 2914

Wellington Industrial Equipment Servicing | Tel 04 589 0350

Nelson Thwaites Diesel Nelson Limited | Tel 03 547 1400

Blenheim Hamilton's Machinery Services | Tel 03 578 5863

Canterbury GMH Technologies | Tel 021 160 8002

Greymouth Colin Homes Hydraulics | Tel 027 435 1850

Otago Ferguson Engineering | Tel 03 489 6452

Southland Industrial Equipment Services | Tel 03 214 4074

Endraulic 85 Montgomerie Road, Mangere, Auckland 2022

Tel + 64 9 274 5059 | 0800 468 782 **Email** info@endraulic.co.nz

Post PO Box 74053, Greenlane, Auckland 1546 **Web** www.endraulic.co.nz

Hours Mon-Fri 8:00am - 5:00pm | Saturday by appointment