

LOADMAX

**Performance.
Strength.
Value.**



WL350E *Spec Sheet*
WHEEL LOADER

WL350E WHEEL LOADER

WL350E Features

- ROPS/FOPS Pillarless Cabin
- Fast Cycle Times
- Articulated frame
- Suspension Seat with Armrest
- Heavy Duty Hydraulic Rams
- 50 point Pre-delivery Inspection
- 2 year / 2000 hour Limited Warranty

Optional Attachments

- Air-conditioning
- Joystick Controller
- Hydraulic Quick Hitch/Aux. Hydraulics
- Pallet Forks/4in1 Bucket/GP Bucket
- Larger Tyres / Turf Tyres / Solid Tyres
- Weighing System
- Auto-Greasing System

Dimensions

A Length (Bucket on ground)	6890mm
B Width outside tyres	2500mm
C Height	3130mm
D Bucket Width	2420mm
E Max. Dump Height (-45° angle)	3260mm
F Wheel Centres	1960mm
G Max. Hinge Pin Height	4210mm
H Wheelbase	2640mm
I Length, no bucket	5790mm
J Front wheel to bucket edge	1110mm

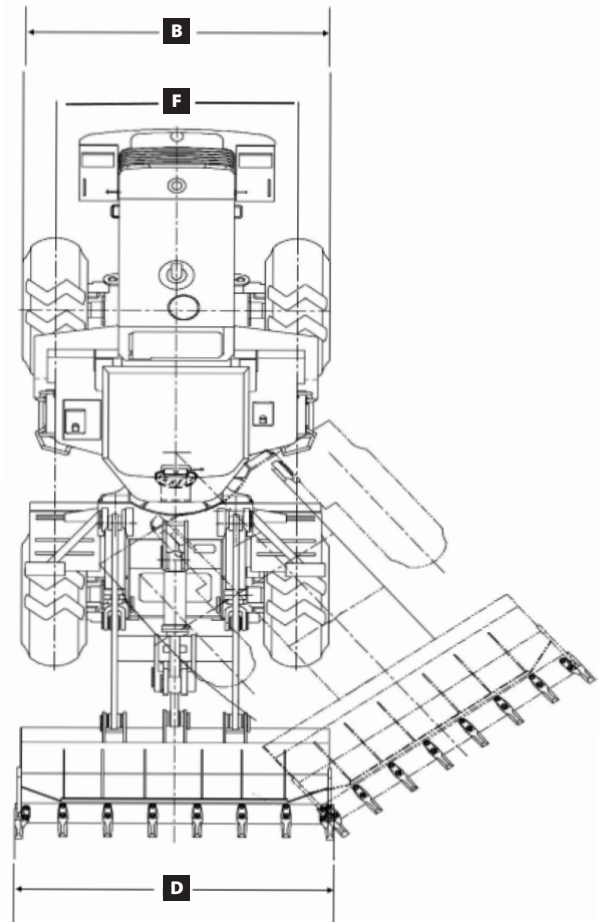
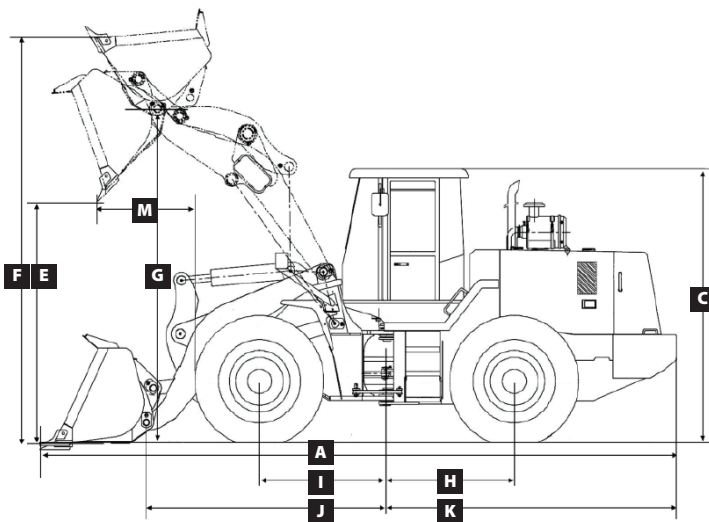

Specifications

Operating Weight	12000kg
Rated Load	3500kg
Static Tipping Load (full turn)	7120kg
Bucket Standard	2.5m ³

Max. Traction Force	10500kgf
Max Breakout force	9750kgf
Min Turning Radius Rear Wheel	5362mm
Min Turning Radius Bucket	5850mm

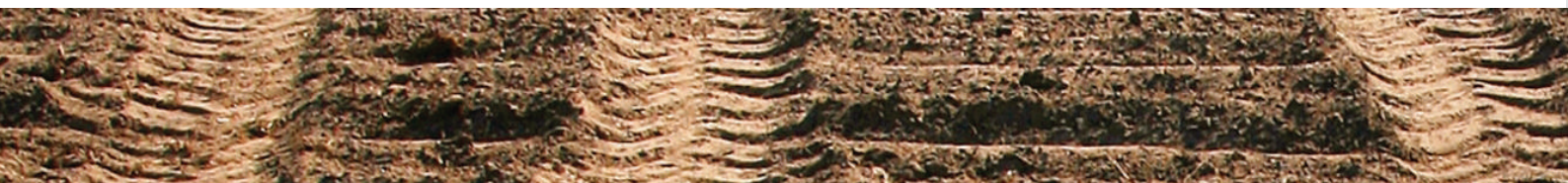

WL350E WHEEL LOADER

Transmission

Torque Converter	Type	Fixed power shift + high/low fixed shaft speed			
	Torque ratio	2.3			
Travel Speed	Speeds	1	2	3	4
	Forward (km/h)	0-10	12	27	35
	Reverse (km/h)	0-10	12	7	12
Transmission	Type	Fixed Power Shift			
	Shift	Forward 4 / Reverse 2			
	Transmission Ratio	Forward 1	3.82		
		Forward 2	2.08		
		Forward 3	1.09		
		Forward 4	0.59		
		Reverse 1	3.05		
		Reverse 2	0.87		
Transmission Pump	Gear driven hydraulic pump				
Working Pressure	2030 Psi				
Main Drive	Type	Single stage, spur gear			
	Gear Ratio	4.222			
Final Drive	Type	Single stage, planetary shift			
	Gear Ratio	4:8			
Driving Axle & Tyres	Type	4WD			
	Mount	Oscillating rear axle, rigid front axle			
	Tyre Size	20.5-25			
Brake System	Service Brake Type	Air over hydraulic disc brakes			
	Parking Brake	Hand Brake			

Steering System

Type	Full hydraulic articulated steering
Steering Pump	Gear driven hydraulic pump - 100L/min
Steering Angle	38°
Working Pressure	2030 Psi

Bucket Options

Standard Material	2.5m ³
Optional Light Material	3.0m ³

Engine

	Standard	Optional
Make	CUMMINS	N/A
Model	6BTA5.9-C150	N/A
Rated Power	110kW	N/A
Rated RPM	2200rpm	N/A
Displacement	5.9L	N/A
Max.Torque	570Nm	N/A
Cylinders	6	

Hydraulics

Type	Gear driven hydraulic
Boom Cylinder Cylinder bore x piston rod diameter x stroke	125x70x771mm
Bucket Cylinder Cylinder bore x piston rod diameter x stroke	140x80x502mm
Pump	Gear driven hydraulic
Working pressure	2320 Psi
Lifting time (Max Load)	6.0s
Lowering time (Empty)	3.1s
Dumping time (Empty)	1.0s
Total Cycle Time	10.1s
MaxAuxiliary Flow	200 L/min

Service Fill Capacities

Fuel	200L
Hydraulic Oil	190L
Axles	2 x 13L
Engine Oil	17.5L
Transmission	25L
Brake System	4L

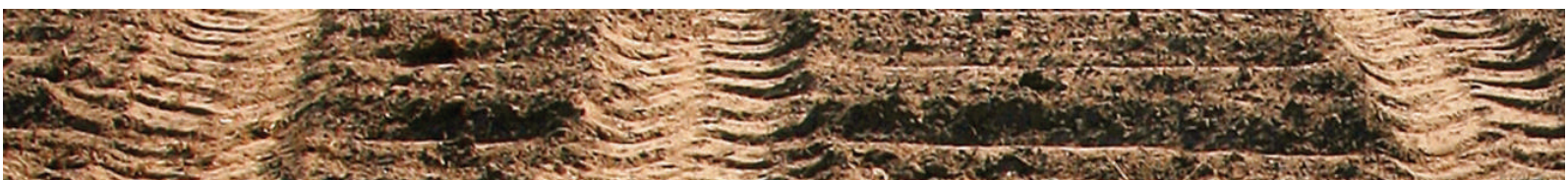

© **Endraulic** **EQUIPMENT**



0800 468 782

SERVICE AGENTS

Auckland Endraulic - Workshop | Tel 0800 468 782

Waikato Pro Mechanical | Tel 07 957 2695

Gisborne Gisborne Hydraulics Ltd | Tel 06 868 6226

Rotorua Top Gear Rotorua Ltd | Tel 0274 707 014

Taupo Taupo Parts & Services | Tel 07 378 2673

Taranaki Muggeridge Diesel Services | Tel 0274 334 747

Wanganui CRV Equipment | Tel 06 348 7860

Palmerston North Central Forklifts | Tel 06 323 1908

Horowhenua McLachlans Services | Tel 027 675 2914

Wellington Industrial Equipment Servicing | Tel 04 589 0350

Nelson Thwaites Diesel Nelson Limited | Tel 03 547 1400

Blenheim Hamilton's Machinery Services | Tel 03 578 5863

Canterbury GMH Technologies | Tel 021 160 8002

Greymouth Colin Homes Hydraulics | Tel 027 435 1850

Otago Ferguson Engineering | Tel 03 489 6452

Southland Industrial Equipment Services | Tel 03 214 4074

Endraulic 85 Montgomerie Road, Mangere, Auckland 2022

Tel + 64 9 274 5059 | 0800 468 782 **Email** info@endraulic.co.nz

Post PO Box 74053, Greenlane, Auckland 1546 **Web** www.endraulic.co.nz

Hours Mon-Fri 8:00am - 5:00pm | Saturday by appointment