



TM

VENIERI
SPA

11.63B

12.63B

13.63B

WHEEL LOADER





100% VENIERI DESIGN

In the new machines our **Venieri Design Center** follows the “family feelings” but introduces significant **stylistic innovations**.



BREATHTAKING VIEW

The new ROPS/FOPS Level II cabin design guarantees **360° visibility**, for **maximum visual control and highest level of safety**.



4K LINKAGE

New completely redesigned linkage to the latest state of the art, for **maximum breakout force**.

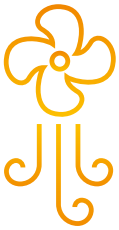

BE COOL

The **brand new ventilation system** guarantees operator comfort. You can choose between the **automatic climate control** or the **air conditioner**, thus obtaining the **perfect temperature in the cabin**.



SILENCE, PLEASE

The choice of new sound absorbent materials and special “anti vibration” rubber shock absorbers **allows a radical noise reduction in cabin, for maximum comfort** for the operator.

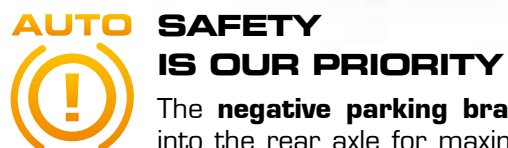

AUTO SAFETY IS OUR PRIORITY

The **negative parking brake** is integrated into the rear axle for maximum safety in all operating situations.

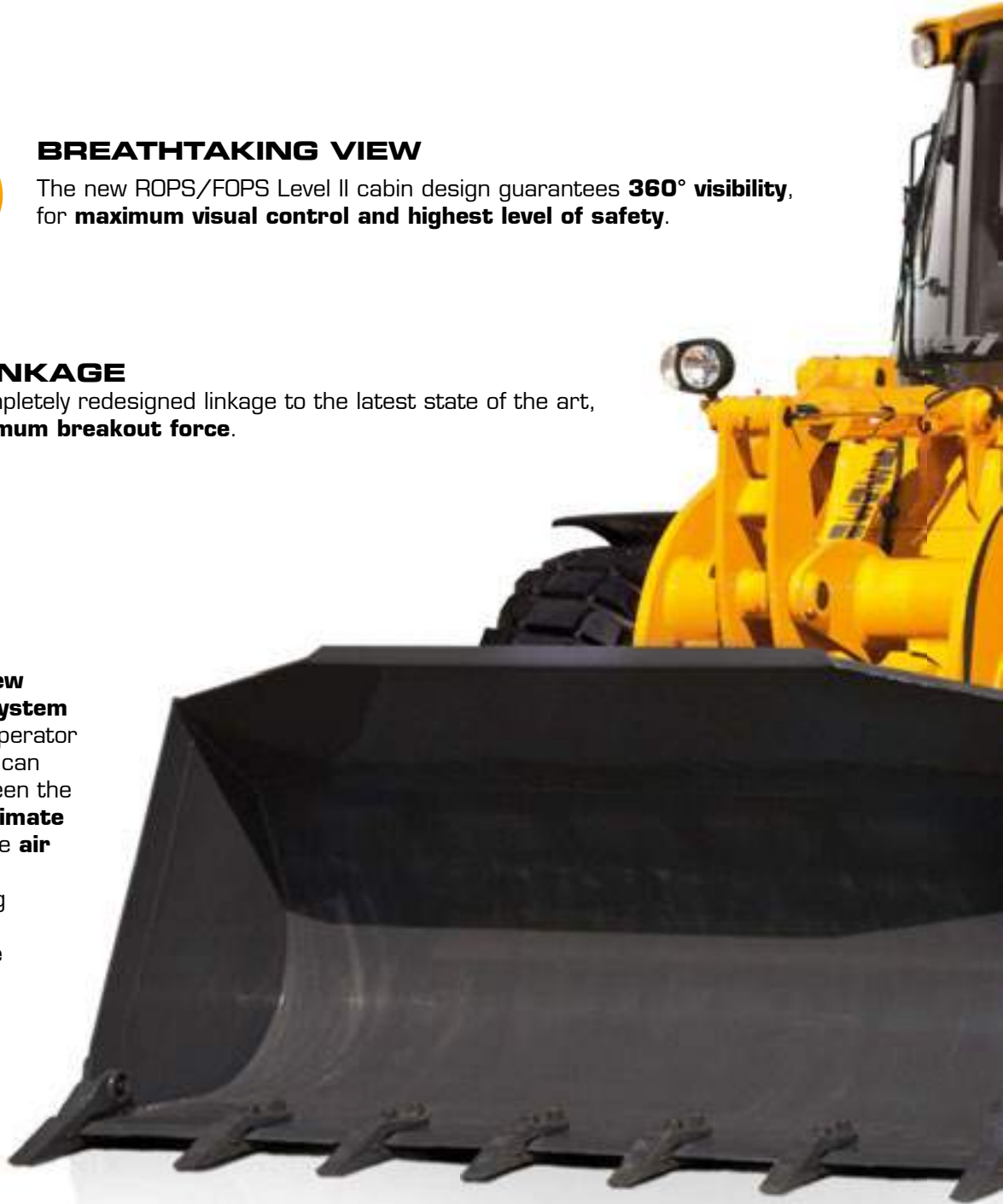



NEW DEUTZ TIER 4i/STAGE IIIB ENGINE

The new Deutz engine complies with the latest emission standards delivering high torque at low rpm.



DOUBLE ATTENTION FOR FUEL SAVING

The new electrically controlled dual speed cooling fan, adjusts the rotation speed according to the working conditions, reducing fuel consumption and noise.



AIR CYCLONE PRECLEANER

ALWAYS CLEAN AIR

The new air cleaner system offers a two stage filtration, through high efficiency primary filters and safety filters, that could be integrate with cyclon pre-filter (optional) for maximum engine protection.



BUILT FOR POWER, DESIGNED FOR AGILITY

The special layout of the counterweight grants perfect maneuverability, maximum drive angle and protection of the integrated rear lights in narrow spaces.



TOTAL STABILITY

Oscillating rear axle fixed to the frame with maintenance-free supports.

11.63B

WHEEL LOADER "Z" LINKAGE



DIESEL ENGINE

4-cylinder in-line engine, turbocharged, direct-injection common rail (DCR®), cooled exhaust gas recirculation, water-cooled, dry filtration, and particle filter with active regeneration. Emissioned according to CEE 97/68 – Stage IIIB/Tier4i.

Type	Deutz TCD 4.1 L4
Max. power	121 kW - 164 HP
Rated rpm	2.200
Power ISO/TR 14396	115 kW - 156 HP
Power EEC 80/1269	115 kW - 156 HP
Economic working range	rpm 1400 - 1800
Max. torque	Nm 609
Bore	mm 101
Stroke	mm 126
Displacement	cm³ 4.038



ELECTRIC SYSTEM

Battery	12 Volt
Capacity EN 60095-1	180 Ah - 1100 A
Alternator rating	95 A
Reverse warning	Standard
Wiring according to	IP 67 - DIN 40050



TRANSMISSION

Hydrostatic transmission with automatic power regulation and closed circuit with variable displacement pumps and two motors. Three forward/reverse speed with fully automatic gear shift and single-lever control. Gear box with automatic gear and clutch to disconnect of one motor during travelling speed.

Work speed	Forward	Reverse
1 st gear km/h	0÷8	0÷8
2 nd gear km/h	0÷17	0÷17
3 rd gear km/h	0÷40	0÷40



AXLES

Two heavy duty axles with planetary final drivers in each wheel. Rigid drive axle on front chassis section. Oscillating drive axle on rear chassis section, up to a total angle of 20°. Transfer gear box transferring movement directly both to rear and front axle through transmission cardan shaft. Self-locking limited slip differential present on front axle, optional on rear one.



BRAKES

Service: hydraulic multi-disc oil brake on each wheel.
Parking: negative hydraulic on rear, electrically activated.



TYRES

Standard	20.5 R 25
Optional	20.5 - 25 / 555/70 R24 / 620/70 R26



STEERING

Servo-assisted steering through **LOAD SENSING** hydraulic power steering with separated pump.

Total steering angle	80°
Inner tyres turning radius	mm 3.130
External turning radius	mm 5.500
External bucket turning radius*	mm 6.050

* Bucket on traveling condition



HYDRAULIC SYSTEM

Single variable displacement piston pump with power control for the loader, second gear pump for the steering circuit. Selector switch for controlling arm movement speed. Modular 2-element control valve. Double acting hydraulic cylinders. Hydraulic oil cooling radiator with fan having a double speed rotation. Full-flow oil filter on the leakage pipe. Single servolever arm-control with 4-positions lifting system and with 3-positions bucket system.

Max flow	lt/1'	160
Loader relief valve pressure	bar	280
Steering relief valve pressure	bar	175
Lift cylinder	mm	110x750
Bucket cylinder	mm	130x455
Lifting time (full)	sec.	5,2
Lowering time (empty)	sec.	4,3
Unloading time	sec.	1,7
Total time of cycle	sec.	11,2



SERVICE CAPACITIES

Engine	lt	11,5
Front axle	lt	20,5
Rear axle	lt	20,5
Gearbox	lt	3,5
Hydraulic circuit	lt	222
Fuel	lt	268
Water cooling	lt	30



TECHNICAL FEATURES

Standard bucket capacity	m³	2,2
Bucket width	mm	2.480
Straight static tipping load	kg	9.700
Full turned 40° tipping load	kg	8.600
Lifting capacity at max. height	kg	8.900
Dump clearance	mm	3.850
Dump height at 42°	mm	2.950
Reach at 42°	mm	950
Breakout force	kg	12.800



DIMENSIONS AND WEIGHT

Max length in transfer position	mm	6.715
Max width in transfer position	mm	2.480
Max Height	mm	3.214
Track width	mm	1.850
Overall tyre width	mm	2.380
Wheel base	mm	2.980
Ground clearance	mm	455
Standard operating weight	kg	12.300
Max permissible weight	kg	13.450

dB NOISE LEVEL

ISO 6396 - LpA (interior pressure level)	dB(A)	69
2000/14/CE - LwA (exterior power level)	dB(A)	102

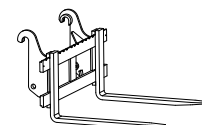
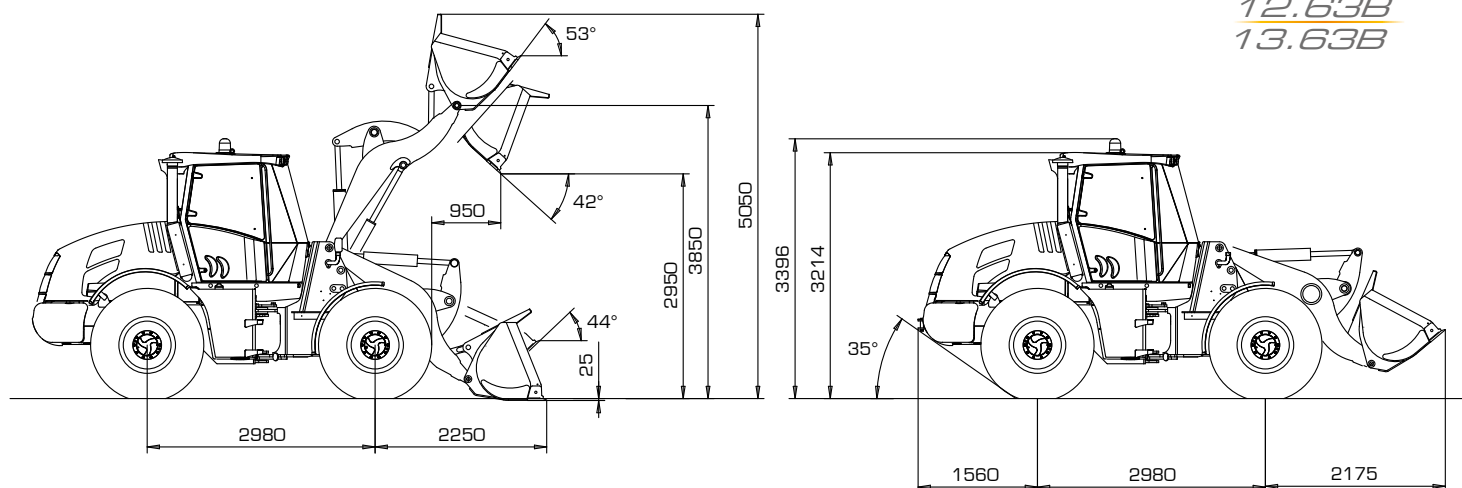

PERFORMANCE DATA

UNIVERSAL BUCKET

ROCK

OVERSIZE

FORKS

		UNIVERSAL BUCKET	ROCK	OVERSIZE	FORKS
Full load bucket capacity (SAE)	m ³	2,2	1,7	2,5	
Bucket width	mm	2.480	2.480	2.540	
Bucket weight	kg	800	700	850	
Max operative height	mm	5.050	5.000	5.125	
Height to hinge pin	mm	3.850	3.850	3.850	
Dump angle	°	42°	42°	42°	
Dump height	mm	2.950	3.000	2.900	
Dump clearance	mm	950	894	1.006	
Dump distance	mm	2.005	1.949	2.061	
Max. dump distance	kg	9.700	10.000	9.200	
Bucket static tipping load, straight	kg	8.600	8.800	8.100	
Bucket static tipping load, full turn	kg	12.800	13.900	11.900	
Breakout force	mm	6.715	6.665	6.790	
Total displacement length	mm	6.050	6.025	6.131	
External bucket turning radius	kg	12.300	12.200	12.350	
Standard operating weight	kg				6.400
Payload EN 474-3 (80%) [•]	kg				5.120
Payload EN 474-3 (60%) [•]	kg				3.840
Payload DIN 24094 (50%)	kg				3.200

[•] Loading center 500 mm

POWER

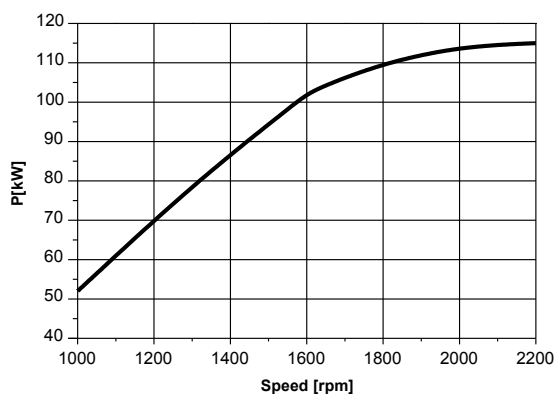

TORQUE

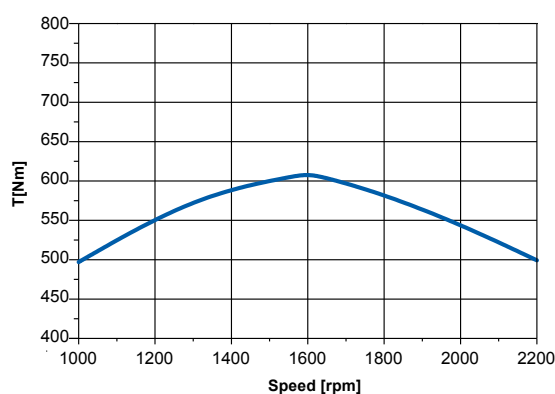

12.63B

WHEEL LOADER PARALLEL LINKAGE



DIESEL ENGINE

4-cylinder in-line engine, turbocharged, direct-injection common rail (DCR®), cooled exhaust gas recirculation, water-cooled, dry filtration, and particle filter with active regeneration. Emissioned according to CEE 97/68 – Stage IIIB/Tier4i.

Type	Deutz TCD 4.1 L4
Max. power	121 kW - 164 HP
Rated rpm	2.200
Power ISO/TR 14396	115 kW - 156 HP
Power EEC 80/1269	115 kW - 156 HP
Economic working range	rpm 1400 - 1800
Max. torque	Nm 609
Bore	mm 101
Stroke	mm 126
Displacement	cm³ 4.038



ELECTRIC SYSTEM

Battery	12 Volt
Capacity EN 60095-1	180 Ah - 1100 A
Alternator rating	95 A
Reverse warning	Standard
Wiring according to	IP 67 DIN 40050



TRANSMISSION

Hydrostatic transmission with automatic power regulation and closed circuit with variable displacement pumps and two motors. Three forward/reverse speed with fully automatic gear shift and single-lever control. Gear box with automatic gear and clutch to disconnect of one motor during travelling speed.

Work speed	Forward	Reverse
1 st gear km/h	0÷8	0÷8
2 nd gear km/h	0÷17	0÷17
3 rd gear km/h	0÷40	0÷40



AXLES

Two heavy duty axles with planetary final drivers in each wheel. Rigid drive axle on front chassis section. Oscillating drive axle on rear chassis section, up to a total angle of 20°. Transfer gear box transferring movement directly both to rear and front axle through transmission cardan shaft. Self-locking limited slip differential present on front axle, optional on rear one.



BRAKE

Service: hydraulic multi-disc oil brake on each wheel.
Parking: negative hydraulic on rear, electrically activated.



TYRES

Standard	20.5 R 25
Optional	20.5 - 25 / 555/70 R24 / 620/70 R26



STEERING

Servo-assisted steering through **LOAD SENSING** hydraulic steering power with separated pump.

Total steering angle	80°
Inner tyres turning radius	mm 3.130
External turning radius	mm 5.500
External bucket turning radius*	mm 6.050

* Bucket on traveling condition



HYDRAULIC SYSTEM

Single variable displacement piston pump with power control for the loader, second gear pump for the steering circuit. Selector switch for controlling arm movement speed. Modular 2-element control valve. Double acting hydraulic cylinders. Hydraulic oil cooling radiator with fan having a double speed rotation. Full-flow oil filter on the leakage pipe. Single servolever arm-control with 4-positions lifting system and with 3-positions bucket system.

Max flow	lt/'	160
Loader relief valve pressure	bar	280
Steering relief valve pressure	bar	175
Lift cylinder	mm	110x769
Bucket cylinder	mm	80x850
Lifting time (full)	sec.	5.1
Lowering time (empty)	sec.	4,3
Unloading time	sec.	2,1
Total time of cycle	sec.	11,5



SERVICE CAPACITIES

Engine	lt	11,5
Front axle	lt	20,5
Rear axle	lt	20,5
Gearbox	lt	3,5
Hydraulic circuit	lt	222
Fuel	lt	268
Water cooling	lt	30



TECHNICAL FEATURES

Standard bucket capacity	m³	2,2
Bucket width	mm	2.480
Straight static tipping load	kg	9.100
Full turned 40° tipping load	kg	8.000
Lifting capacity at max. height	kg	7.400
Dump clearance	mm	4.000
Dump height at 42°	mm	3.100
Reach at 42°	mm	1.050
Breakout force	kg	9.500



DIMENSION AND WEIGHT

Max length in transfer position	mm	6.930
Max width in transfer position	mm	2.480
Max Height	mm	3.214
Track width	mm	1.850
Overall tyre width	mm	2.380
Wheel base	mm	2.980
Ground clearance	mm	455
Standard operating weight	kg	12.500
Max permissible weight	kg	13.450

dB NOISE LEVEL

ISO 6396 - LpA (interior pressure level)	dB(A)	69
2000/14/CE - LwA (exterior power level)	dB(A)	102

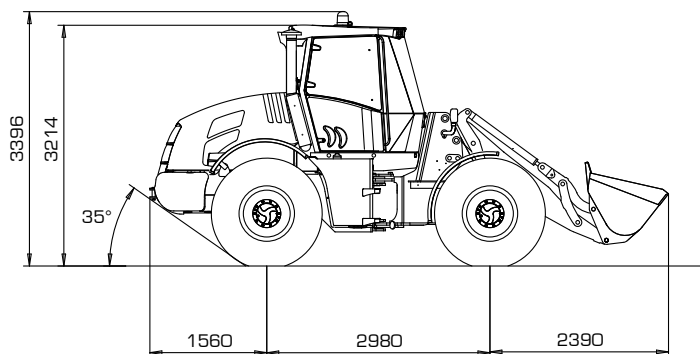
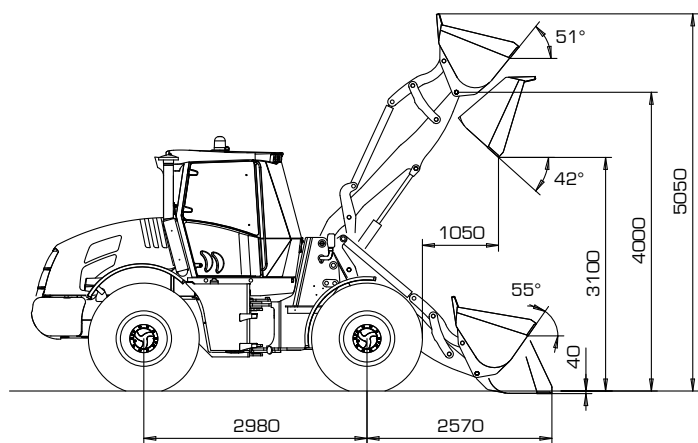

UNIVERSAL BUCKET



ROCK



OVERSIZE

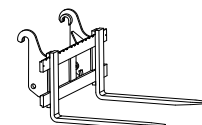

FORKS



PERFORMANCE DATA

Full load bucket capacity (SAE)	m ³	2,2	1,7	2,5	
Bucket width	mm	2.480	2.480	2.540	
Bucket weight	kg	800	700	850	
Max operative height	mm	5.050	5.000	5.125	
Height to hinge pin	mm	4000	4.000	4.000	
Dump angle	°	42°	42°	42°	
Dump height	mm	3.100	3.200	3.100	
Dump clearance	mm	1050	938	1.050	
Dump distance	mm	2.175	2.063	2.175	
Max. dump distance	kg	9.100	9.400	8.800	
Bucket static tipping load, straight	kg	8.000	8.400	7.800	
Bucket static tipping load, full turn	kg	9.500	11.176	9.500	
Breakout force	mm	6.930	6.805	7.005	
Total displacement length	mm	6.050	6.000	6.080	
External bucket turning radius	kg	12.500	12.400	12.550	
Standard operating weight	kg				6.500
Payload EN 474-3 (80%) [•]	kg				5.200
Payload EN 474-3 (60%) [•]	kg				3.900
Payload DIN 24094 (50%)	kg				3.250

[•] Loading center 500 mm

POWER

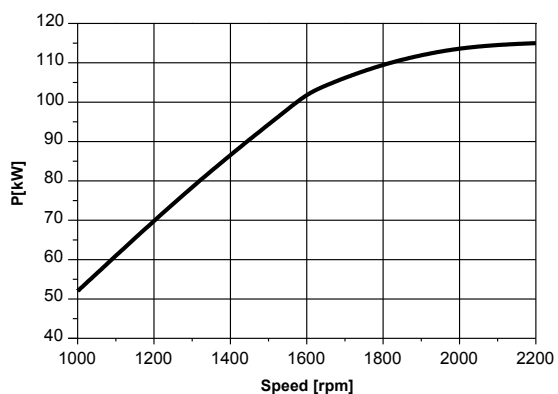

TORQUE

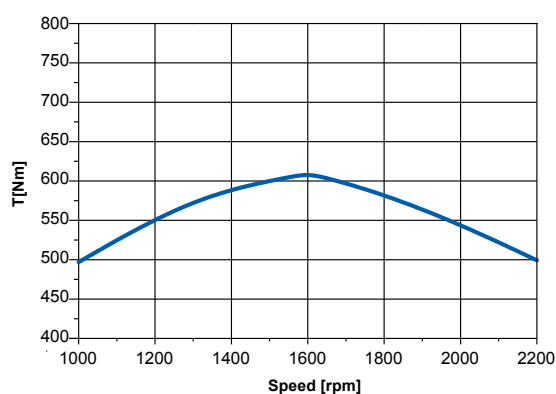

13.63B

WHEEL LOADER "Z" LINKAGE



DIESEL ENGINE

6-cylinder in-line engine, turbocharged, direct-injection common rail (DCR®), cooled exhaust gas recirculation, water-cooled, dry filtration, and particle filter with active regeneration. Emissioned according to CEE 97/68 - Stage IIIB/Tier4i.

Type	Deutz TCD 6.1 L6
Max. power	135 kW - 184 HP
Rated rpm	2.200
Power ISO/TR 14396	129 kW - 175 HP
Power EEC 80/1269	129 kW - 175 HP
Economic working range	rpm 1200 - 1700
Max. torque	Nm 750
Bore	mm 101
Stroke	mm 126
Displacement	cm ³ 6.057



ELECTRIC SYSTEM

Battery	12 Volt
Capacity EN 60095-1	180 Ah - 1100 A
Alternator rating	95 A
Reverse warning	Standard
Wiring according to	IP 67 DIN 40050



TRANSMISSION

Hydrostatic transmission with automatic power regulation and closed circuit with variable displacement pumps and two motors. Three forward/reverse speed with fully automatic gear shift and single-lever control. Gear box with automatic gear and clutch to disconnect of one motor during travelling speed.

Work speed	Forward	Reverse
1 st gear km/h	0÷8	0÷8
2 nd gear km/h	0÷17	0÷17
3 rd gear km/h	0÷40	0÷40



AXLES

Two heavy duty axles with planetary final drivers in each wheel. Rigid drive axle on front chassis section. Oscillating drive axle on rear chassis section, up to a total angle of 20°. Transfer gear box transferring movement directly both to rear and front axle through transmission cardan shaft. Self-locking limited slip differential present on front axle, optional on rear one.



BRAKES

Service: hydraulic multi-disc oil brake on each wheel.
Parking: negative hydraulic on rear, electrically activated.



TYRES

Standard	20.5 R25
Optional	20.5 - 25 / 620/70 R26



STEERING

Servo-assisted steering through **LOAD SENSING** hydraulic steering power with separated pump.

Total steering angle	80°
Inner tyres turning radius	mm 3.130
External turning radius	mm 5.500
External bucket turning radius*	mm 6.150

* Bucket on traveling condition



HYDRAULIC SYSTEM

Single variable displacement piston pump with power control "P.C.S." for the loader, second gear pump for the steering circuit. Selector switch to control arm movement speed. Modular 2-element control valve. Double acting hydraulic cylinders. Hydraulic oil cooling radiator with fan having a double speed of rotation. Full-flow oil filter on the leakage pipe. Single servo-lever-arm-control with 4-position lifting system and with 3-position bucket system.

Max flow	lt/1'	195
Loader relief valve pressure	bar	280
Steering relief valve pressure	bar	175
Lift cylinder	mm120x750	
Bucket cylinder	mm130x485	
Lifting time (full)	sec.	5,0
Lowering time (empty)	sec.	1,7
Unloading time	sec.	4,1
Total time of cycle	sec.	10,8



SERVICE CAPACITIES

Engine	lt	15,5
Front axle	lt	20,5
Rear axle	lt	20,5
Gearbox	lt	3,5
Hydraulic circuit	lt	222
Fuel	lt	268
Water cooling	lt	30



TECHNICAL FEATURES

Standard bucket capacity	m ³	2,7
Bucket width	mm	2.540
Straight static tipping load	kg	10.800
Full turned 40° tipping load	kg	9.600
Lifting capacity at max. height	kg	10.500
Dump clearance	mm	3.950
Dump height at 42°	mm	3.050
Reach at 42°	mm	1.050
Breakout force	kg	12.000



DIMENSIONS AND WEIGHT

Max length in transfer position	mm	6.950
Max width in transfer position	mm	2.540
Max Height	mm	3.214
Track width	mm	1.850
Overall tyre width	mm	2.380
Wheel base	mm	2.980
Ground clearance	mm	455
Standard operating weight	kg	13.700
Max permissible weight	kg	14.150

dB NOISE LEVEL

ISO 6396 - LpA (interior pressure level)	dB(A)	68
2000/14/CE - LwA (exterior power level)	dB(A)	101

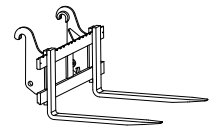
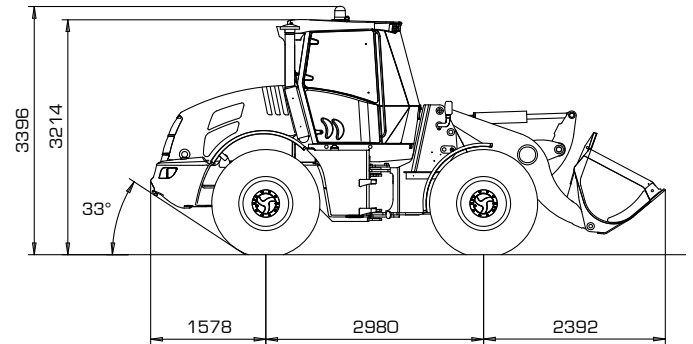
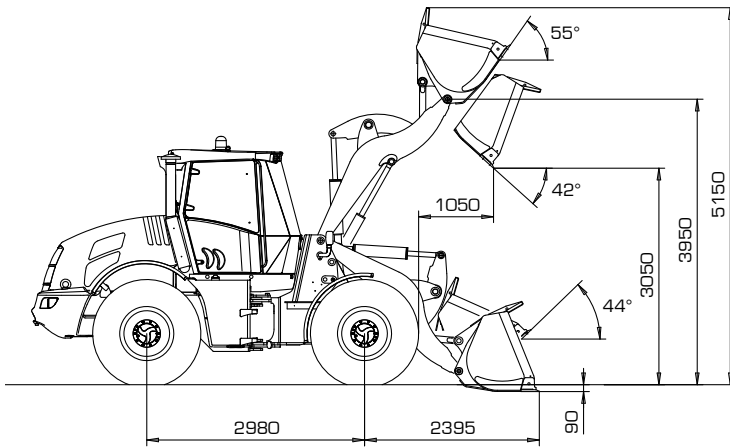

PERFORMANCE DATA

UNIVERSAL BUCKET

ROCK

OVERSIZE

FORKS

Full load bucket capacity (SAE)	m ³	2,7	2,2	3,0	
Bucket width	mm	2.540	2.540	2.540	
Bucket weight	kg	900	850	950	
Max operative height	mm	5.150	5.100	5.225	
Height to hinge pin	mm	3950	3.950	3.950	
Dump angle	°	42°	42°	42°	
Dump height	mm	3.050	3.100	3.017	
Dump clearance	mm	1050	994	1.087	
Dump distance	mm	2.025	1.969	2.062	
Max. dump distance	kg	10.800	11.000	10.400	
Bucket static tipping load, straight	kg	9.600	9.700	9.200	
Bucket static tipping load, full turn	kg	12.000	12.973	11.478	
Breakout force	mm	6.950	6.825	7.025	
Total displacement length	mm	6.150	6.125	6.200	
External bucket turning radius	kg	13.700	13.650	13.750	
Standard operating weight	kg				7.000
Payload EN 474-3 (80%) [•]	kg				5.600
Payload EN 474-3 (60%) [•]	kg				4.200
Payload DIN 24094 (50%)	kg				3.500

[•] Loading center 500 mm

POWER

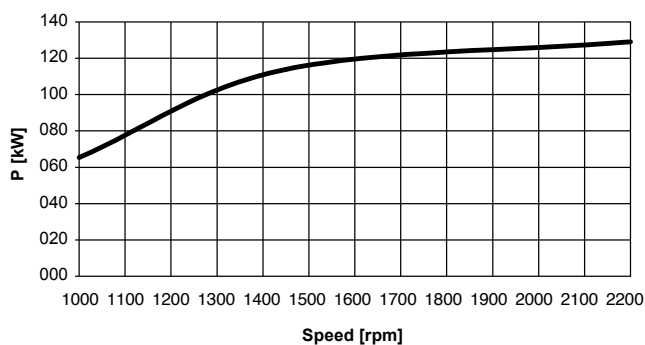

TORQUE

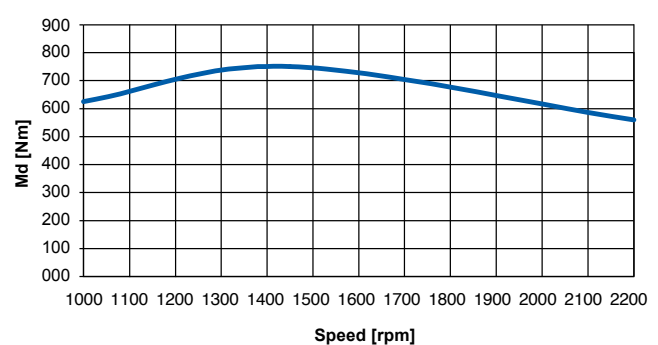

THE NEW CABIN

A BREATHTAKING VIEW. AUTOMOTIVE COMFORT.

Getting on board, is certainly the best way to appreciate the **ergonomics and comfort** of the cabin. We know that a **spacious and comfortable working environment** reduces stress and increases productivity: therefore in the cabin you will find **wide interior space, on hand controls**, with optimized ergonomics and **excellent 360° visibility** and with all available equipments. Immediately after having switched on the engine, you can appreciate the **great soundproofing** identifying the cabs of Venieri wheel loaders.

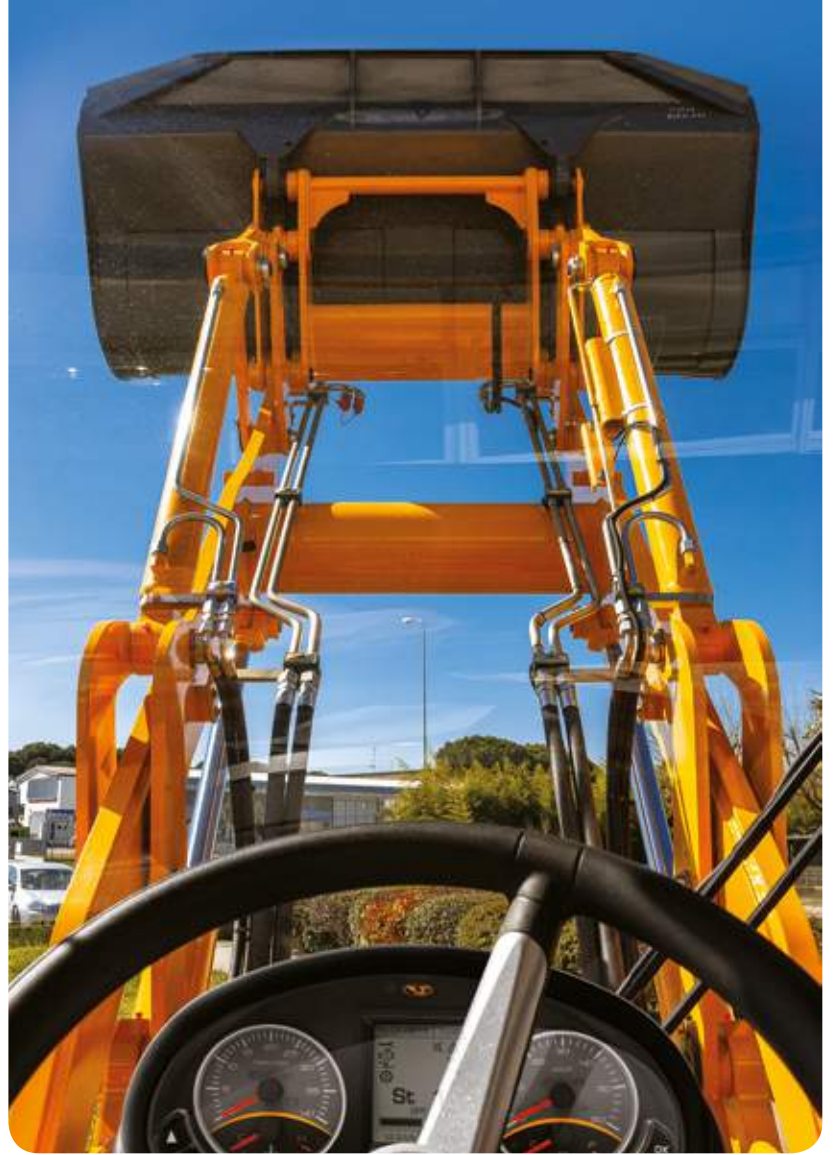



We have **minimized "blind spots"** for **superb visibility** in all working conditions.



THE BIG BROTHER.

You'll have eyes everywhere. An advanced **camera system installed on all 4 sides of the cabin** (optional) allows you to keep **everything under control** could recording everything that happens around you. For Venieri the operator protection for us comes first!

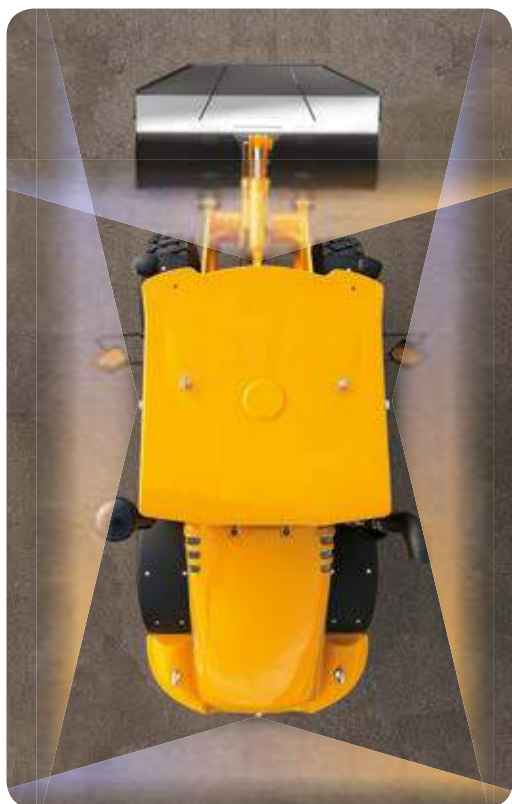

FINALLY BEAUTY MEETS FUNCTIONALITY.

With the new cab of VF 11.63B, 12.63B, 13.63B the Venieri Design Center tried to merge **functionality** and **style** for maximum simplicity use. The result is a cabin whose design is optimally suited to any **operator's necessity**. Spacious, efficient and ergonomic: it offers ideal conditions for a **comfortable and productive work**.



19/07/2016	10:20
	123
	123
St 1	123
DPF:	
12.3 l/h	123 h

LAYOUT A

19/07/2016	10:30
Total working hours	123 h
Partial working hours	123 h
12.3 l/h	123 h

LAYOUT B

19/07/2016	10:40
Average consumption	123 l/h
Total consumption	123 l
Instantaneous consumption	12.3 l/h
12.3 l/h	123 h

LAYOUT C

19/07/2016	10:50
	Remaining Hours
	123
12.3 l/h	123 h

LAYOUT D

ARTIFICIAL INTELLIGENCE.

Advanced man/machine interface, for constant **monitoring of machine's performances**, communicating **each diagnosis** to the operator by a large and detailed LCD screen positioned in the dashboard.

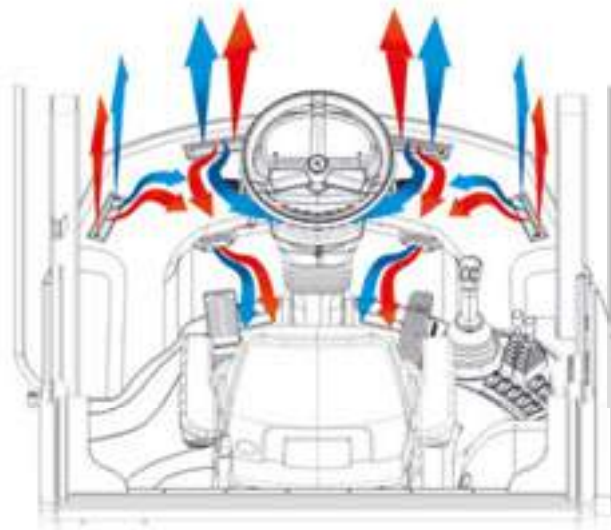
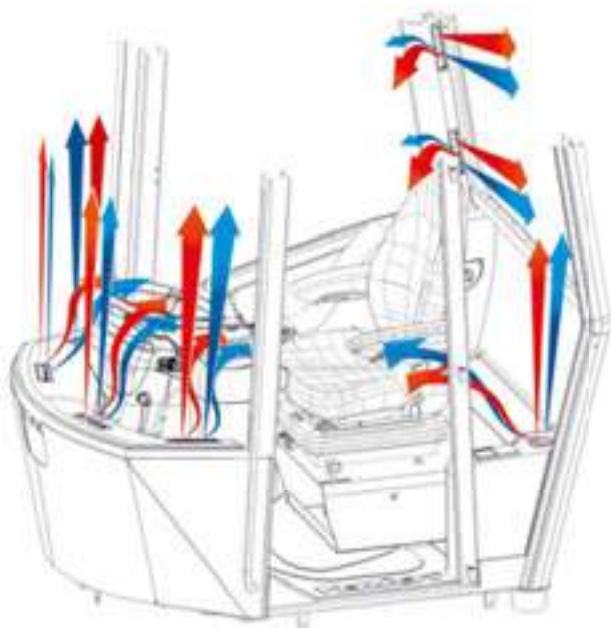

BE COOL

The entire ventilation system has been redesigned for the maximum comfort. With a single dashboard, the operator can choose the ideal temperature, ensuring **maximum working comfort**. The VF 11.63B, VF12.63B and VF13.63B can be equipped with **Venieri Climatronic** (optional). You have only to set the temperature, and the Venieri Climatronic will keep everything under control.



 **Bluetooth™**

**BLUETOOTH
SOUND SYSTEM SPEAKER**

The VENIERI Bluetooth™ radio (optional) allows you to operate in absolute security, ensuring a perfect hands-free connection on your wheel loader.

LUMBAR
SETTING →

LUMBAR
SETTING →

SETTING ONLY
ON INCLINATION PILLOW →

PILLOW SETTING
FORWARD/REVERSE →



ENJOY THE SHOW.

The **driver's seat** is equipped with the **most advanced solutions in terms of comfort** for maximum operational efficiency. Also the seat with pneumatic suspension, is available, with anti-shock system, additional regulations on the pillow and lumbar adjustment (optional).

CLASS EVOLUTION.

CLEAN POWER, ZERO CONSUMPTION. NEW DEUTZ TIER 4/STAGE IIIB ENGINES

The VF 11.63B, VF 12.63B and VF 13.63B is powered by the **new Deutz TCD 4.1 L04 e TCD 6.1 L6** four cylinder 4038cm³ and six cylinder 6057 cm³ unit **awarded as best engine in his class**. The impressive performance, reliability and durability distinguishing this engine have been made possible by adopting the most advanced technology, such as: **electronically controlled Common Rail injection, turbocharger with intercooler**.

Due to **gas after-treatment system of waste (EAT)** such motors ensure **optimum performances** guaranteeing a **fuel consumption and operating costs**. Excellent cold start performances even in extreme conditions.

The size and design of the engines will remain identical in the transition to Stage V, thanks to profound design analysis. A version without the post-treatment of exhaust gas system (EAT) is available as an option for less regulated markets.

› COMMON RAIL

In Deutz engines, injection pressures of **1,600 bar** ensure that the fuel is perfectly atomised for **maximized combustion efficiency**, which not only **reduces fuel consumption** but also **increased torque and power**.

› FILTER DPF

The engines comply with the emission requirements of **EU Stage IIIB and US EPA Tier 4 interim**. Thanks to a **particulate filter (DPF)** the **regeneration of the filter** takes place without interference on the operation under all operating conditions.

› ENGINE MANAGEMENT

The powerful **DEUTZ Common Rail injection system (DCR®)** and the **electronic engine control (EMR 4)**, ensure **optimum engine performance and low fuel consumption**.



13.63B

Deutz TCD 6.1 L6
135 kW - 184 HP

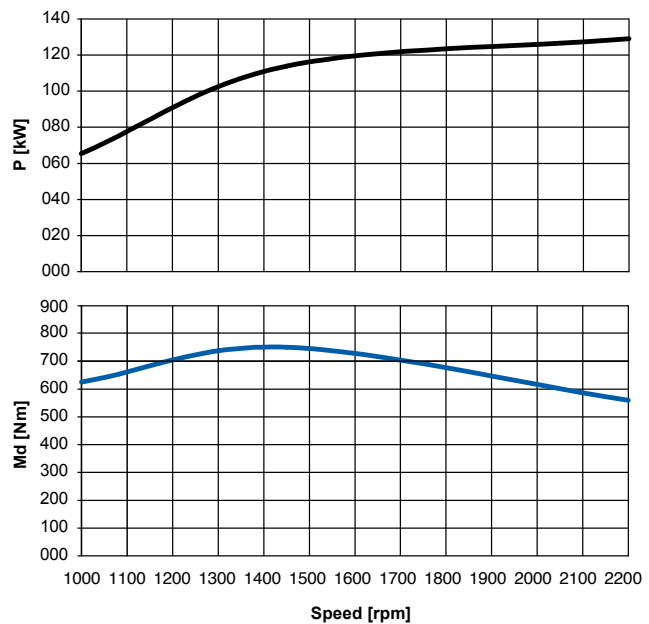

**11.63B
12.63B**

Deutz TCD 4.1 L4
121 kW - 164 HP

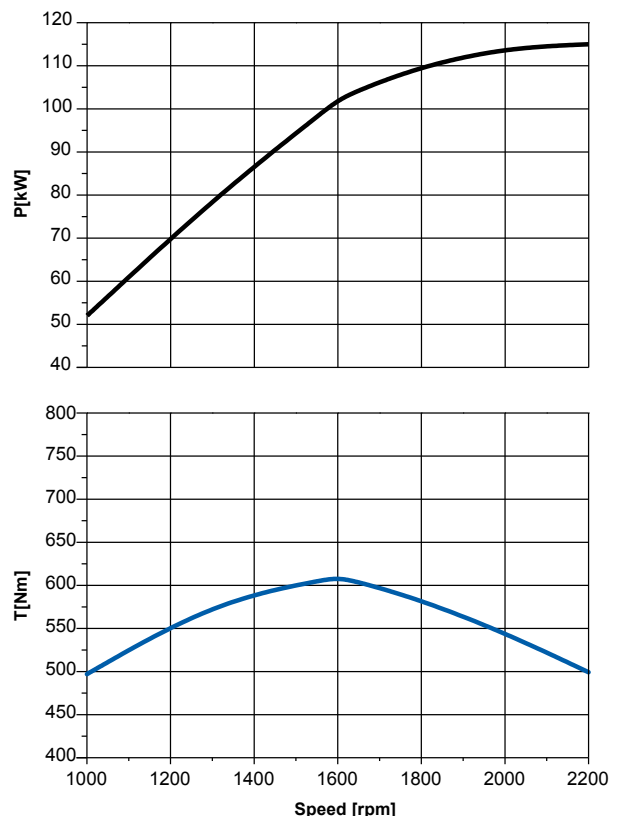

SILENCE, PLEASE.

Noiselessness inside the new cab is simply **extraordinary**.
Only 68 dB.

**+ VIBRATIONS
+ dB INSIDE
CABIN**

Vibrations are inevitably generated by the hydraulic flow system.

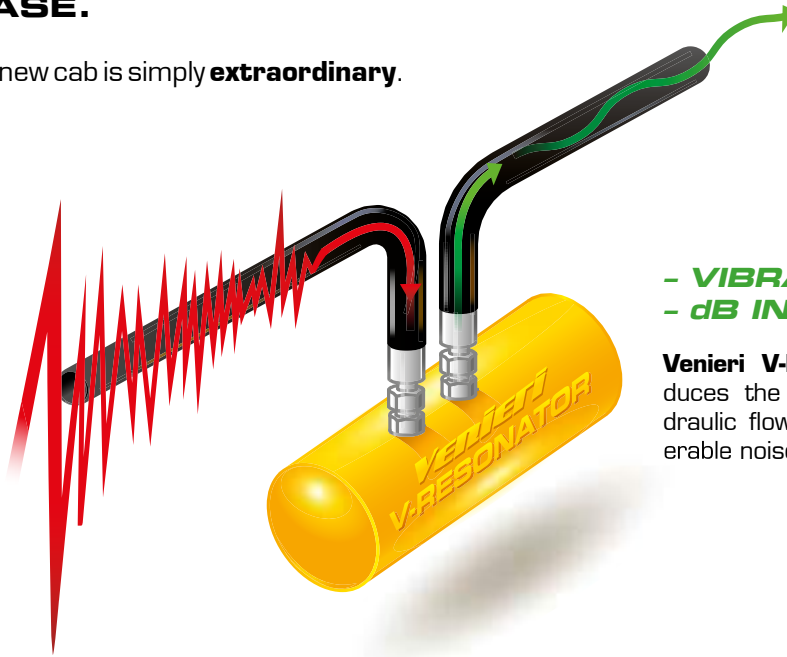

**68dB
INSIDE
CABIN**

**- VIBRATIONS
- dB INSIDE
CABIN**

Venieri V-Resonator drastically reduces the vibrations caused by hydraulic flow, thus ensuring a considerable noise suppression in the cabin.

VROOOOOOOM!

Driving speed of **40 km/h** selflimited. We are in the Motor Valley and the speed is not an option. [limited to specific country regulation (TUV)].



MAXIMUM POWER EXACTLY WHERE YOU NEED IT.

A lot of power for the hydraulic system and, at the same time, a reduction of the travel speed. For these reasons VF 11.63B, 12.63B and 13.63B wheel loaders need a single pedal. The brake pedal with **inching function** controls both the mechanical brake and the hydraulic one (inching). This gives real advantages as **less wear of the service brake** and **optimum distribution of engine power**.



No pressure
on the inching/brake pedal:
maximum power for traction.



Normal pressure
on the inching/brake pedal:
on speed reduction, and more power
the hydraulic system service.



Maximum pressure
on the inching/brake pedal:
the wheel loader stops,
maximum strength to the hydraulic system.

HARD OR SMOOTH?

It's possible to select three operating modes from different work requirements. In each mode, the **Venieri Power Control** system manages the total torque of the engine and of the pump, ensuring constantly an adequate **hydraulic penetration force** and considerable **consumption control**.



FULLPOWER MODE

Ideal conditions of use with Asphalt planer, Snow blower and any other application where it is required maximum hydraulic capacity.

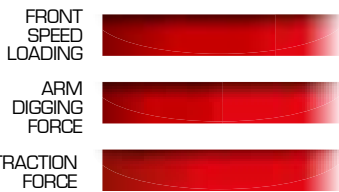

PRECISION MODE

Ideal conditions of use with forks, handling heavy loads and precision works.

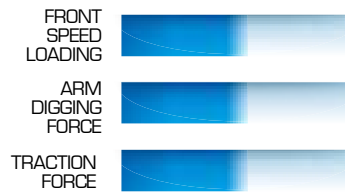

AUTOMATIC MODE

Ideal condition of use providing the optimal balance between consumption and operational capacity.

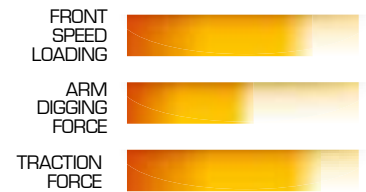

DARKNESS DOESN'T SCARE US.

LED projectors, 6 working lights on cabin roof plus 4 additional headlights for road transfer will allow you to work in safety and total autonomy, in all working conditions!



DON'T GET HEATED!

The new wheel loaders VF 11.63B, VF 12.63B and VF 13.63B are able to work longer thanks to smart features, such as the **automatic cooling fan**.

The **reversible fan kit** allows a **facilitated cleaning** of the **radiator through a rotation in the opposite direction**, the duration and the number of cleaning cycles are chosen and discretion of the operator, according to the working conditions. (option)



EASY ACCESS MAINTENANCE

The VF 11.63B, VF 12.63B and VF 13.63B wheel loaders are designed to **make faster and simple all routine maintenance procedures**. The engine/radiator bonnet can be opened completely, providing practical and easy access for daily checks. This ensures the **highest efficiency level to the machine** whenever it has to work, ensuring you plenty of time concentrating on the job to do.

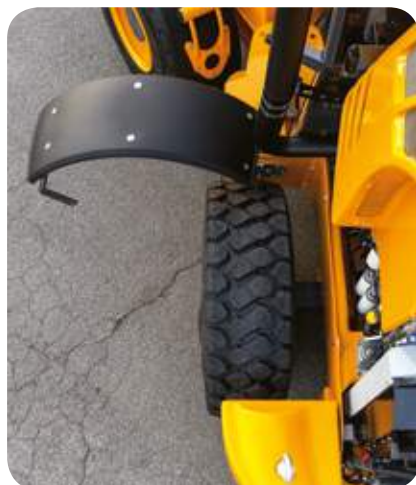

Venieri GLOBAL

Venieri GLOBAL™ is the newest Venieri monitoring system by Satellite allowing increased productivity, providing detailed information on the fleet and equipment, as well as an incredible amount of data for ensuring the highest levels of performances and in greater economic efficiency.

- › FLEET MANAGEMENT
- › MONITORING MACHINES
- › CONTROL MACHINES STATUS

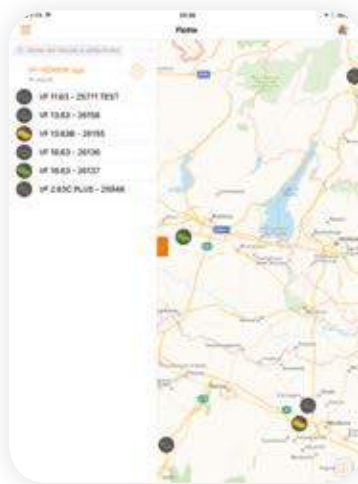

MONITORING FLEET



PRODUCTIVITY REPORT



Available, on Windows e Mac, iOS and Android.



REPORT ALARMS



ENGINE ON/OFF



▶ **BASIC MACHINE**



Battery main switch	•	•	•
Tool box	•	•	•
Fuel preheating (cold climates)	0	0	0
Plugs with keys for fuel and hydraulic tanks	•	•	•
Proportional self lock front differential	•	•	•
Proportional self lock rear differential	0	0	0
Differential lock 100% engageable in front axle	0	0	0
Trailer coupling	•	•	•
Warning beacon	•	•	•
Soundproofing	•	•	•
Spare parts catalogue	•	•	•
User manual	•	•	•
Type-approval for road traffic	•	•	•
Safety clamp for bucket and lifting cylinders	•	•	•
Autolevelling ground level for bucket	•	•	•
Speed reduction kit	0	0	0
"Venieri GLOBAL" system	0	0	0
Double-speed hydraulic fan	•	•	•
Reversible fan (for radiator cleaning)	0	0	0
Hydraulic negative parking brake	•	•	•
Service brake on both axles with separate circuits	•	•	•
Inch pedal integrated in brake pedal	•	•	•
Greasing points grouped on the frame	•	•	•
Automatic centralized greasing system	0	0	0
Ride control	0	0	0
Engine preheating system	0	0	0
Environmental friendly hydraulic oil	0	0	0
Hydraulic oil ISO 46 (cold climates)	0	0	0
Vortex pre filter	0	0	0

▶ **CABIN EQUIPMENT**



ROPS/FOPS 2nd Level, pressurized and soundproofed	•	•	•
Front and rear windscreen wiper with washer	•	•	•
Halogen work lights (4 front + 2 rear)	•	•	•
LED work lights (4 front + 2 rear)	0	0	0
Ashtray	•	•	•
Bottle holder	•	•	•
Document compartment	•	•	•
Seat with mechanical suspension	•	•	•
Seat with pneumatic suspension	0	0	0
Seat with pneumatic suspension and heating	0	0	0
Seat armrests	•	•	•
Buzzer	•	•	•
Cabin carpet	•	•	•
Clothes hangers	•	•	•
Radio preparation	•	•	•
Supplementary socket 12V	•	•	•
Manual Air Conditioning	•	•	•
"Climatronic Venieri" system	0	0	0
Ceiling lamp	•	•	•
Sun visor	•	•	•
Rear view mirrors	•	•	•
Heatable rear view mirrors	0	0	0
First-aid kit	0	0	0
Fire extinguisher 2kg	0	0	0
Seat belt	•	•	•
Instrumentation and dashboard with LCD display	•	•	•
Safety glass breaker	•	•	•
Rear view camera with 7" color monitor	0	0	0
Cameras 360°	0	0	0

▶ **SPECIAL EQUIPMENT**



Hydraulic or mechanical quick coupler	0	0	0
Cement mixing bucket	0	0	0
Multipurpose bucket (4 in 1)	0	0	0
Lifting forks	0	0	0
Asphalt and cement planer	0	0	0
Snow blower	0	0	0
Snow blade and "V" type snow blade	0	0	0
Angle-tilt dozer blade	0	0	0
Hand operating hammer	0	0	0
Polishing brush	0	0	0
Trencher	0	0	0
High tip bucket	0	0	0
High flow kit	0	0	0
Unpressurized return pipe	0	0	0
Double auxiliary line	0	0	0
Rear hydraulic line (single effect)	0	0	0



Via Piratello, 106 - 48022 Lugo (RA) - ITALY
Tel. +39 0545 904411 Fax +39 0545 30389
e-mail: info@vf-venieri.com | www.vf-venieri.com

Spare Parts
Tel. +39 0545 904429 Fax +39 0545 24555
e-mail: ricambi@vf-venieri.com

(2017) UP1163B1263B1363B_A-EN proartigrafica.it