

LOADMAX

**Performance.
Strength.
Value.**



WL500E *Spec Sheet*
WHEEL LOADER

WL500E WHEEL LOADER

WL500E Features

- ROPS/FOPS Pillarless Cabin
- Fast Cycle Times
- Articulated frame
- Suspension Seat with Armrest
- Heavy Duty Hydraulic Rams
- 50 point Pre-delivery Inspection
- 2 year / 2000 hour Limited Warranty

Dimensions

A Length (Bucket on ground)	7920mm
B Width outside tyres	3050mm
C Height	3400mm
D Bucket Width	3020mm
E Max. Dump Height (-45° angle)	3200mm
F Wheel Centres	2220mm
G Max. Hinge Pin Height	4100mm
H Wheelbase	3400mm
I Length, no bucket	6790mm
J Front wheel to bucket edge	1130mm

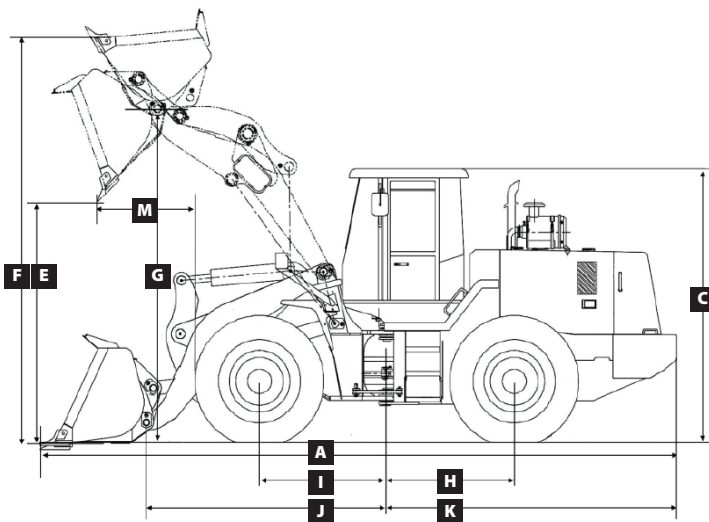

Specifications

Operating Weight	17100kg
Rated Load	5000kg
Static Tipping Load (full turn)	10200kg
Bucket Standard	3m ³

Optional Attachments

- Air-conditioning
- Joystick Controller
- Hydraulic Quick Hitch/Aux. Hydraulics
- Pallet Forks/4in1 Bucket/GP Bucket
- Larger Tyres / Turf Tyres / Solid Tyres
- Weighing System
- Auto-Greasing System

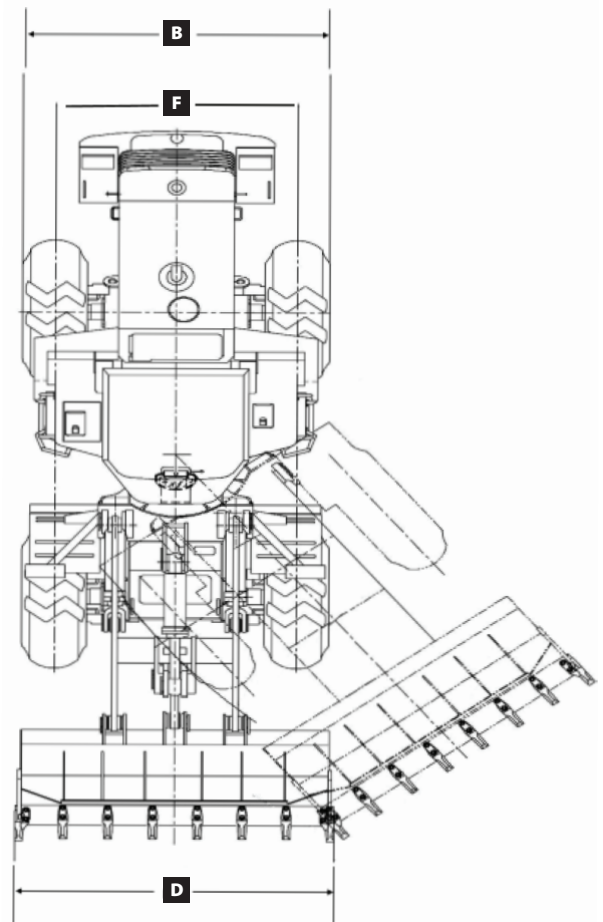

Max. Traction Force	17265kgf
Max Breakout force	18355kgf
Min Turning Radius Rear Wheel	6036mm
Min Turning Radius Bucket	6879mm

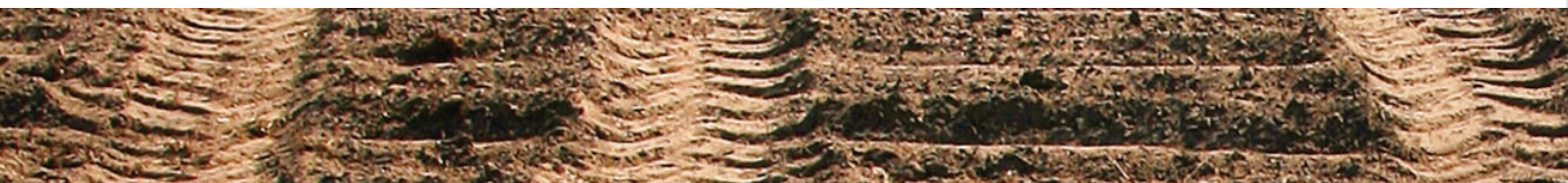

WL500E WHEEL LOADER

Transmission

Torque Converter	Type	Fixed power shift + high/low fixed shaft speed			
	Torque ratio	2.55			
Travel Speed	Speeds	1	2	3	4
	Forward (km/h)	15	38	N/A	N/A
	Reverse (km/h)	15	N/A	N/A	N/A
Transmission	Type	Fixed Power Shift			
	Shift	Forward 2 / Reverse 1			
	Transmission Ratio	Forward 1	2.155		
		Forward 2	2.578		
		Forward 3	N/A		
		Forward 4	N/A		
		Reverse 1	1.577		
		Reverse 2	N/A		
	Transmission Pump	Gear driven hydraulic pump			
Working Pressure	2030 Psi				
Main Drive	Type	Single stage, spur gear			
	Gear Ratio	4.625			
Final Drive	Type	Single stage, planetary shift			
	Gear Ratio	4:94			
Driving Axle & Tyres	Type	4WD			
	Mount	Oscillating rear axle, rigid front axle			
	Tyre Size	23.5-25			
Brake System	Service Brake Type	Air over hydraulic disc brakes			
	Parking Brake	Hand Brake			

Steering System

Type	Full hydraulic articulated steering
Steering Pump	N/A
Steering Angle	38°
Working Pressure	2030 Psi

Bucket Options

Standard Material	3m ³
Optional Light Material	4.5m ³

Engine

	Standard	Optional
Make	WEICHAH	CUMMINS
Model	WD10G220E23	6QSB6.7-C215
Rated Power	162kW	162kW
Rated RPM	2000rpm	2200rpm
Displacement	6.75L	6.7L
Max.Torque	900Nm	910Nm
Cylinders	6	

Hydraulics

Type	Gear driven hydraulic
Boom Cylinder Cylinder bore x piston rod diameter x stroke	165x90x767mm
Bucket Cylinder Cylinder bore x piston rod diameter x stroke	190x100x545mm
Pump	Gear driven hydraulic
Working pressure	2610 Psi
Lifting time (Max Load)	5.5s
Lowering time (Empty)	3.0s
Dumping time (Empty)	1.2s
Total Cycle Time	9.7s
Max Auxiliary Flow	260 L/min

Service Fill Capacities

Fuel	220L
Hydraulic Oil	210L
Axles	2 x 32L
Engine Oil	22.6L
Transmission	35L
Brake System	4L

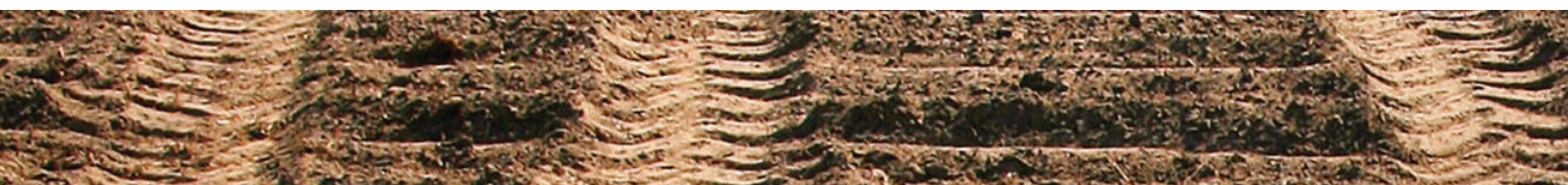

© **Endraulic** **EQUIPMENT**



0800 468 782

SERVICE AGENTS

Auckland Endraulic - Workshop | Tel 0800 468 782

Waikato Pro Mechanical | Tel 07 957 2695

Gisborne Gisborne Hydraulics Ltd | Tel 06 868 6226

Rotorua Top Gear Rotorua Ltd | Tel 0274 707 014

Taupo Taupo Parts & Services | Tel 07 378 2673

Taranaki Muggeridge Diesel Services | Tel 0274 334 747

Wanganui CRV Equipment | Tel 06 348 7860

Palmerston North Central Forklifts | Tel 06 323 1908

Horowhenua McLachlans Services | Tel 027 675 2914

Wellington Industrial Equipment Servicing | Tel 04 589 0350

Nelson Thwaites Diesel Nelson Limited | Tel 03 547 1400

Blenheim Hamilton's Machinery Services | Tel 03 578 5863

Canterbury GMH Technologies | Tel 021 160 8002

Greymouth Colin Homes Hydraulics | Tel 027 435 1850

Otago Ferguson Engineering | Tel 03 489 6452

Southland Industrial Equipment Services | Tel 03 214 4074

Endraulic 85 Montgomerie Road, Mangere, Auckland 2022

Tel + 64 9 274 5059 | 0800 468 782 **Email** info@endraulic.co.nz

Post PO Box 74053, Greenlane, Auckland 1546 **Web** www.endraulic.co.nz

Hours Mon-Fri 8:00am - 5:00pm | Saturday by appointment