



Excavator SWE 40UB



Operating Weight	4.13t/4.14t
Engine Power	23.8kW/2300rpm
Engine Brand	KUBOTA
Standard Bucket Capacity	0.11m ³
Max. Digging Depth	2.85m

Excavator SWE40UB

Parameter

ENGINE

Brand	KUBOTA
Model	D1803-M-DI-E3B-SWD-1
Type	3-cylinder 4-stroke water-cooled
Displacement	1.826L
Power	23.8kW/2300rpm

ELECTRIC SYSTEM

Nominal Voltage	12V
Batteries	63Ah
Alternator	12V-55A
Starter	12V-2.0kW

DRIVE

Max. Travel Speed (2nd/1st)	5/2.9km/h
Gradeability	30°
Max. Traction	33.5kN

UNDERCARRIAGE

Undercarriage Width	1740mm
Shoe Width	300mm
Length to Center of Rollers	1650mm
Track Length	2143mm
Track Height	522mm

BULLDOZING BOARD

independent moving, controlled by the gear shift lever	
Length X Width	1740X349mm
Max. Lifting Height	345mm
Max. Cutting Depth	370mm

DIMENSIONS

Counterweight Clearance	567mm
Tail Swing Radius	860mm
Shipping Length	4950mm
Transport Width	1745mm
Shipping Height	2540mm

WORKING RANGES

Max. Cutting Height	5002mm
Max. Loading Height	3502mm
Max. Digging Depth	2850mm
Max. Vertical Wall Digging Depth	2593mm
Max. Digging Reach	5441mm
Max. Reach at Ground Level	5302mm
Bucket Digging Force	26.4kN
Stick Digging Force	20.9kN
Ground Pressure	36kPa
Swing Speed	10.5rpm

CAPACITY

Fuel Tank	40L
Hydraulic Oil Tank	43L

HYDRAULIC SYSTEM

Main Pumps	
Type	2 variable displacement pumps, 1 gear pump
Displacement	2x37+26L/min
Working Pressure	23.5/20MPa

Excavator SWE 40UB

Working Ranges

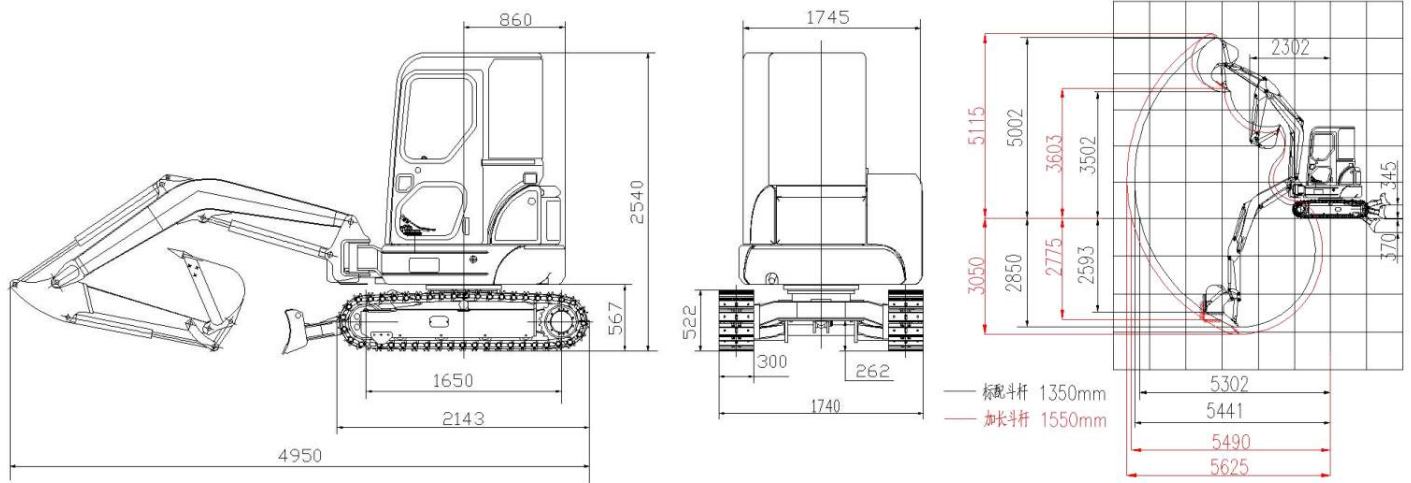

Load Capacity

B(m)	A(m)	MAX		4.0m		3.0m		2.0m	
		Front(kg)	Side(kg)	Front(kg)	Side(kg)	Front(kg)	Side(kg)	Front(kg)	Side(kg)
3.0		669.90*	457.50	665.55*	761.25	970.05*	810.00	—	—
2.0		712.40*	390.00	891.75*	753.15	1035.30*	843.75	1196.25*	1125.00
1.0		765.60*	375.00	887.40*	483.75	1335.45*	753.75	1922.70*	1029.25
0.0		783.00*	393.75	1035.30*	472.50	1183.20*	705.00	1583.40*	1065.00
-1.0		783.00*	435.00	835.20*	487.50	1039.65*	652.50	1583.40*	978.75
-2.0		506.40*	501.60*	—	—	501.60*	501.60*	554.30*	544.70*

Notes:

- 1) Load with * is limited by hydraulic capacity and based on ISO 10567. Rated loads do not exceed 87% of hydraulic capacity.
- 2) Load without * is limited by tipping load and based on ISO 10567. Rated loads do not exceed 75% of tipping load.



47 Rennie Dr, Mangere

Auckland 2022

0800 468 782

P +64 9 274 5059

F +64 9 274 0244

www.endraulic.co.nz

